



# INSTALLATION INSTRUCTIONS

## AUT-1012W Wall Hung ADA Flush Valve Bowl

- (A) Regular Screwdriver
- (B) Adjustable Wrench
- (C) Marker
- (D) Tape Measure
- (E) Level
- (F) Silicone Sealant
- (G) Putty Knife
- (H) Flush Valve (Sold Separately, Not Included)
- (I) Closet Carrier/Support (Not Included)

### Recommended Tools & Materials

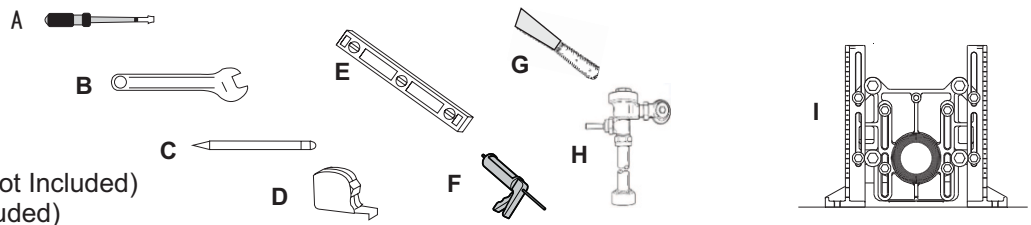

### ⚠ CAUTION: PRODUCT IS FRAGILE

Handle with care to avoid breakage and possible injury!

**Note:** Views in this illustration are for general representation and may not necessarily define the exact contours of the product.



For installations where consideration is given for ADA compliance, the seat height must be 17" to 19" (432mm to 483mm) from the finished floor.

If replacing an existing toilet, be certain to shut off water supply before removing old toilet.

### Wall Hung ADA Flush Valve Bowl Installation

Model: AUT-1012W

**1** For typical installation of the wall hung toilet bowl, a 4-bolt Carrier/Support system, (not supplied with this unit) must be used for attaching the water closet to the carrier/support system and waste drain. Refer to the Installation Instructions that were supplied with the Closet Carrier/Support System for installation of the unit.

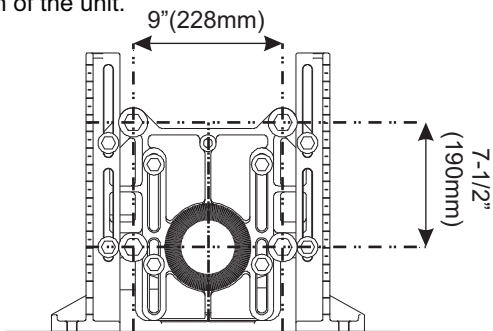

Front View

**2** If you are installing the toilet on an existing support system, make sure the system is in compliance with local code requirements and the support system is weight rated for the application requirements.

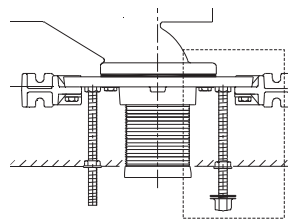

Top View of Carrier

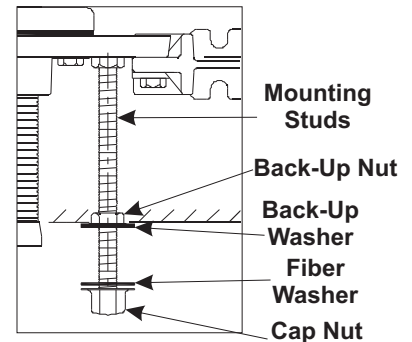

Cut Away of Mounting Hardware

**3** Mounting studs should extend 2-1/8" (54mm) beyond the finished wall.

The waste horn should extend 5/16" (8mm) beyond the finished wall.

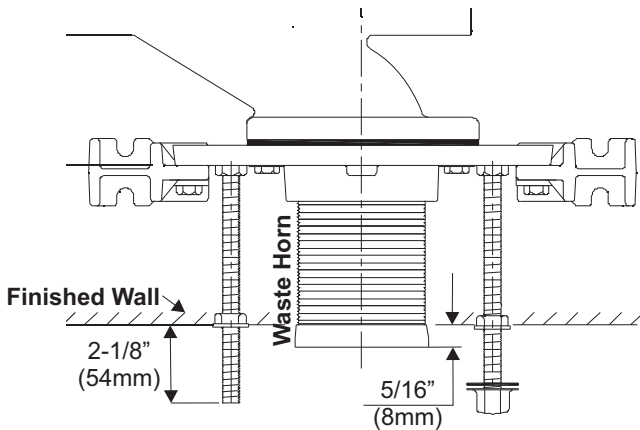

**4** Place back-up nuts supplied with the carrier/support on mounting stud #1, #3 and #4. **No back-up nut is used on mounting stud #2!** Adjust the two lower back-up nuts so the front face of the nuts are 1/16" away from the finished wall. Using a level, adjust the back-up nut on mounting stud #1 to a vertical plane with mounting stud #3. Place back-up washer on the three installed back-up nuts.

**Note:** If the wall is irregular, the three back-up nuts and washers must be positioned to allow a minimum of 1/16" gap between the fixture and the wall.

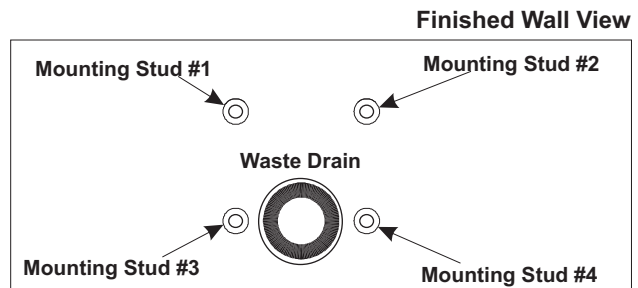

AUT-1012W  
Rev. 4/16



# INSTALLATION INSTRUCTIONS

## AUT-1012W Wall Hung ADA Flush Valve Bowl

**5** **Note:** The back-up nuts, also referred to as the bearing nuts, must be set to take the full load from the fixture while allowing a 1/6"(2mm) clearance between the fixture and the finished wall.

Follow the carrier manufacturer's recommendation settings for the outlet connection.

When setting fixture onto the carrier, it is **not recommended to use a wax ring**, felt or neoprene are recommended.

When setting the fixture to the carrier, the waste gasket must be compressed sufficiently to assure a positive gas and watertight seal.

**6** Using two people, install the bowl onto the fixture mounting studs.

Place the fiber washer supplied with the carrier/support on mounting studs #1, #3 and #4. **(Do not place a fiber washer or cap nut on mounting stud #2 at this time.)**

Place the cap nut supplied with the carrier/support on mounting studs #1, #3 and #4. While holding the bowl level and using an adjustable wrench, tighten the three cap nuts until they are snug.

**▲ CAUTION: PRODUCT IS FRAGILE**  
Do not over tighten nuts more than a snugfit.

**7** Install the fiber washer and cap nut onto the mounting stud #2, hand tighten until the nut and washer are touching the china. Hand snug firmly the cap nut against the china, this is all that is necessary for mounting the cap nut and washer to stud #2.

Caulk sealant into the gap between the toilet and the finished wall.

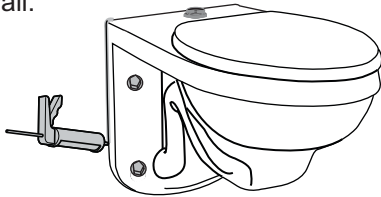

**▲ Note: If you wrench tighten the cap nut on mounting stud #2 you will break the china since there is no back nut on this stud.**

### Care and Maintenance

When cleaning your fixtures, wash it with mild, soapy water, rinse thoroughly with clear water and dry with a soft cloth.

Avoid detergents, disinfectants, or cleaning products in aerosol cans.

**NEVER** use abrasive scouring powders or abrasive pads on your fixture. Some bathroom chemicals and cosmetics may damage the fixture finish.

**Caution: Product is Fragile.**  
**To avoid breakage and possible injury handle with care!**

## One (1) Year Limited Warranty

AMTC warrants its vitreous china to be free of defects in material and workmanship for a period of one (1) year from date of purchase, when properly installed and under normal use and service. A defective product may be returned to AMTC, or its authorized representatives, within one (1) year from date of purchase with the proper invoice of purchase. AMTC, at its discretion, will replace or repair defective product at no charge. Claims for labor, transportation, and any other incidental costs will not be allowed. AMTC will not be responsible for any considerable damages of any kind whatsoever.

For Technical Support:  
Call Toll Free: 800-874-7822  
Email: [technicalsupport@AMTcorporation.com](mailto:technicalsupport@AMTcorporation.com)  
Web: [www.AMTcorporation.com](http://www.AMTcorporation.com)

Make sure to visit our website periodically for information on new products and to download any important documents that you may need in the future.



Advanced Modern Technologies Corporation  
19800 Nordhoff Place, Chatsworth, CA 91311 USA  
Toll Free Tel: 800-874-7822 • Tel: 818-883-2682 • Fax: 818-883-2620  
[sales@AMTcorporation.com](mailto:sales@AMTcorporation.com) • [www.AMTcorporation.com](http://www.AMTcorporation.com)

AUT-1012W  
Rev. 4/16