



HYBRIDFLUSH[®] AUTOMATIC

ADA Floor Mount High Efficiency Flush Valve System

Model
AEFC1012AT16DF

Description

Hardwired, Sensor Operated HYBRIDFLUSH[®] Top Mount Complete HET System with Concealed Dual-Flush Automatic Water Closet Flushometer and Top Spud ADA Vitreous China Fixture.



Flush Cycle

- Model AEFC1012AT16DF (1.6 gpf/6.0 Lpf and 1.1 gpf/4.2 Lpf)

Specifications

Flushometer Specification (Model AEF-801DF-CCT-16)

- User present for less than 60 seconds initiates a reduced flush (1.1 gpf/4.2 Lpf) eliminating liquid and paper waste
- User present for more than 60 seconds initiates a full flush (1.6 gpf/6.0 Lpf) eliminating solid and paper waste
- Reduced flush consumes up to 30% less water
- Patented BRV[®] and Gear Motor Drive
- Wall Mounted Plate with Sensor
- Hands Free Infrared Sensor Activation
- Vandal and Water Resistant Design
- Chrome Plated All Metal Housing
- Quiet Operation
- Electronic Flush Button
- Operates on 6-Volt DC Power (Transformer Sold Separately)
- Adjustable Sensor Distance
- Optional Three (3) Second Flush Delay Mode
- Optional 24-Hour Flush Mode
- Uses Proprietary Silicone Diaphragm with Filtered Bypass
- 1" I.P.S. Angle Stop
- Adjustable Tailpiece
- High Back Pressure Vacuum Breaker with Single Piece Hex Coupling Nut
- Spud Coupling and Flange for 1 1/2" Top Spud
- Sweat Solder Kit and Wall Flange with Set Screw
- High Efficiency For Water Conservation



The HYBRIDFLUSH[®] Advantage

The HYBRIDFLUSH[®] is a revolutionary full-featured automatic flush valve system. The HYBRIDFLUSH[®] incorporates a unique patented mechanism that allows for unsurpassed reliability. The HYBRIDFLUSH[®] by Advanced Modern Technologies Corporation is the most efficient, economical, and complete automatic flush valve system on the market.

Compliance & Certifications

- ASSE 1037-2015
- ASME A112.1035-2015
- CSA B125.37-15



For Finish Variations Please Consult Factory

Accessories (Add suffix to model number for accessories)

- AMCTTRANS6VDC - 6-Volt AC/DC Transformer

Fixture Specification (Model AUT-1012A)

- Complies with ADA Accessible Standards
- White Color
- Vitreous China
- Floor Mount Water Closet Bowl
- Elongated Rim
- 10" (254mm) Rough-In
- 1-1/2" (38mm) I.P.S. Top Spud Inlet
- 2" (50mm) Fully Glazed Trapway
- 11-1/2" (292mm) x 13" (330mm) Water Surface Area
- Direct Feed Jet
- 100% Factory Tested
- Toilet Seat Not Included

Compliance & Certifications

- ASME A112.19.2/CSA B45.1
- Energy Act of 1992
- ADA- With installation consideration for section 604 Water Closets, Accessibility Guidelines.
- ICC/ANSI A117.1
- TAS - With installation consideration for section: 4.16.3. Adult seat height 17" (432mm) to 19" (483mm).
- CSA B651 - With installation consideration for Clause 4.3.6 of the standard.
- ICC-ES PMG[®] Certified



Warranty
5 Years



ADA Compliant

Architect/Engineer Approval

Job Name	_____
Date	_____
Model Specified	_____
Quantity	_____
Variations Specified	_____
Customer/Wholesaler	_____
Contractor	_____
Architect	_____

Plumbing System Requirements

- Minimum Flowing Pressure: 25 PSI
- Maximum Static Pressure: 80 PSI
- Minimum Flow Rate: 25 GPM

The information contained in this document is subject to change without notice.
Revision (05/18)



HYBRIDFLUSH[®] AUTOMATIC

ADA Floor Mount High Efficiency Flush Valve System

Model
AEFC1012AT16DF

Specifications

Operation:	Automatic
Outer Casing:	Standard-Chrome Metal
Operating Water Pressure:	15 PSI - 100 PSI
Sensor Type:	Infrared
Power Type:	6-Volt DC Power
Arming Delay:	5 Seconds
Flush Delay:	3 Seconds
Sensing Range:	18" (45cm) - 30" (75cm) Adjustable
Ghost Flush:	Once Every 24 Hours From Last Flush
Sensor Angle:	Fixed Angle
Flush Cycle:	Specified by Model
Model AEFC1012AT16DF	1.6 gpf/6.0 Lpf and 1.1 gpf/4.2 Lpf
Flush Mode:	After Every Use
Manual Override:	Electronic Flush Button

Dimensions

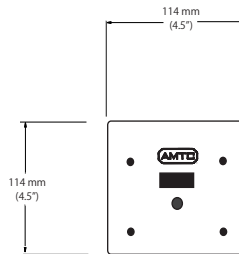
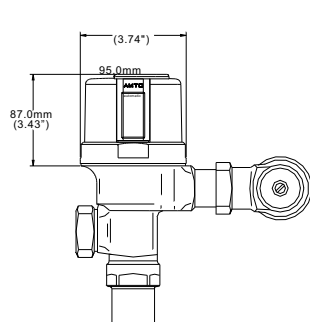

Application

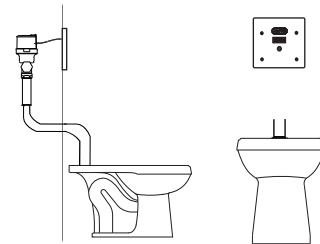

HYBRIDFLUSH[®] shown on water closet (toilet) with electrical flush button.

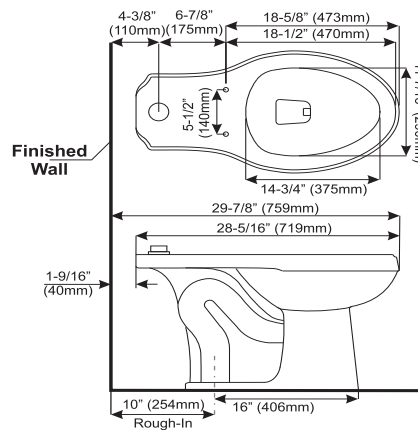
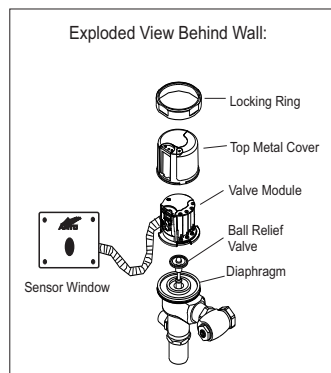

Elongated Rim Nominal Dimensions:
28-5/16" (719mm) Long
15-7/16" (392mm) Wide
17-1/8" (435mm) High

Note: This toilet is designed to rough-in at the standard dimension of 10" (254mm) and 12" (305mm) from the wall to the C/L of the outlet.

This drawing reflects a 10" (254mm) rough-in and additional calculations must be considered for a 12" (305mm) or any other dimensional rough-in.

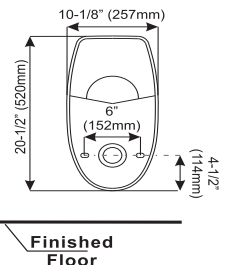
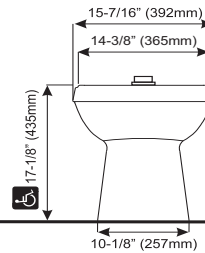

Disclaimer

Note: All vitreous china dimensions shown in these drawings are nominal and not to scale. Dimensions can vary within the tolerances established in the governing ASME A112.19.2/CSA B45.1 standard. It is important to consider this when planning rough-in and plumbing layouts.

Advanced Modern Technologies Corporation • 19800 Nordhoff Place • Chatsworth, CA 91311
Tel: (818) 883-2682 • Toll Free: (800) 874-7822 • Fax: (818) 883-2620 • www.amtccorporation.com